

INDEX OF BOONE COUNTY STANDARDS
900 SERIES STANDARD DRAWINGS
STREET SIGNS

Typical Street Sign Locations.....BC-900-001

Typical Street Sign Details.....BC-900-002

STOP SIGN

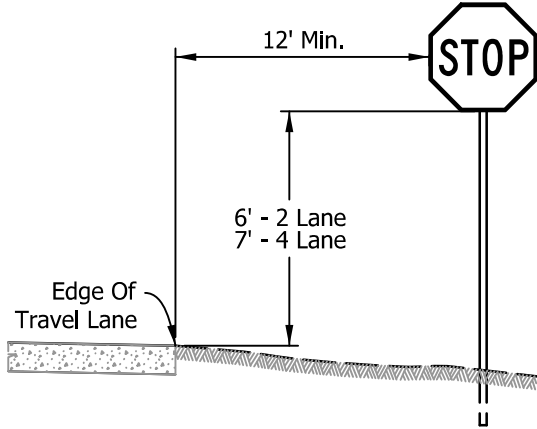

ROADSIDE SIGN

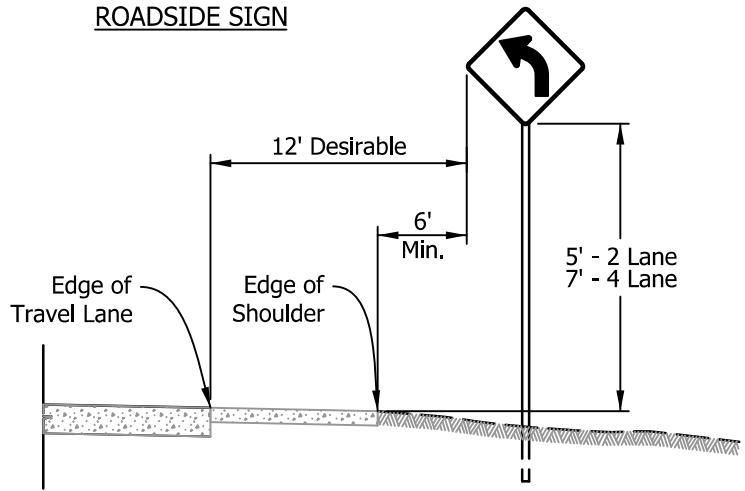

CURBED SECTION

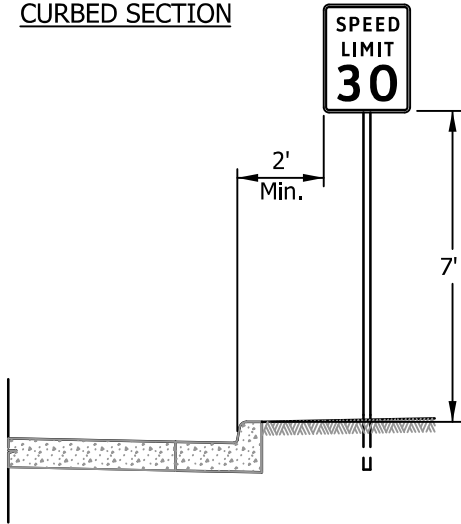

ROADSIDE SIGN & SPEED PLAQUE

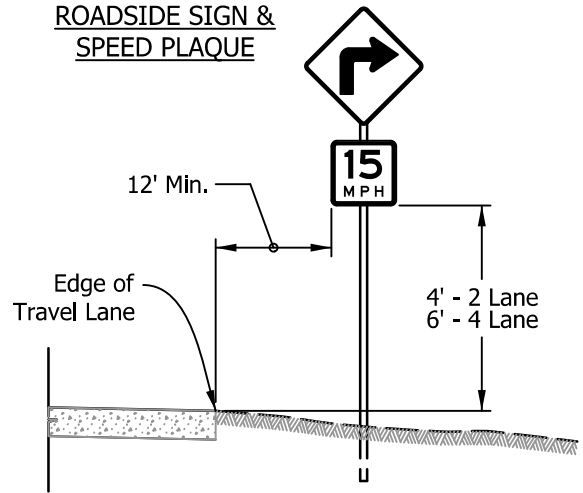

NOTES:

- 1. See MUTCD Section 2A.19 For Reduced Lateral Offset Distances, 2' May Be Used In Areas Where Lateral Offsets Are Limited.
- 2. For Additional Information See MUTCD.
- 3. All Signs Shall Have H.I.P. Retroreflective Backgrounds.
- 4. All Sign Posts Shall Be Mounted On Breakaway Anchors.

ROADSIDE ASSEMBLY

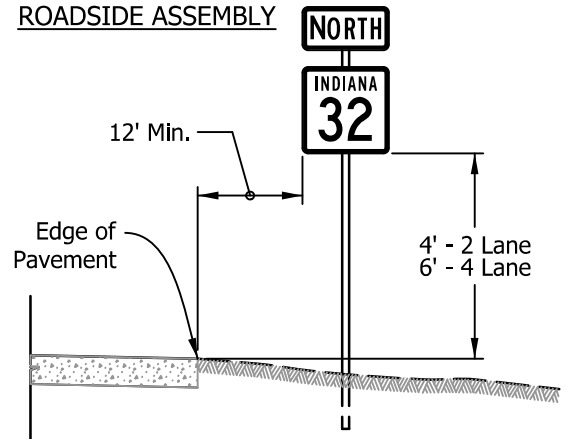

BOONE COUNTY HIGHWAY DEPARTMENT

**POSITION OF SIGNS IN RELATION TO ROADWAY
(CONVENTIONAL ROADS AND STREETS)**

STANDARD DRAWING
NO. BC-900-001
SHEET 1 OF 1
SCALE: NO SCALE



STREET SIGN

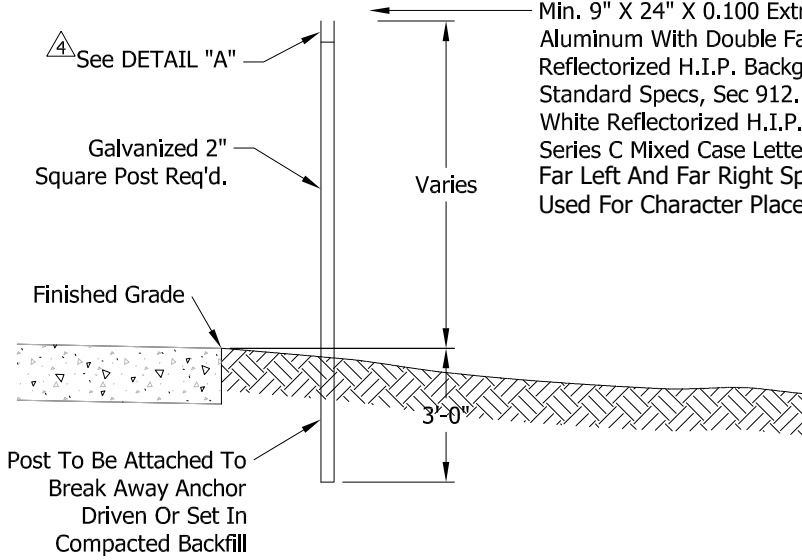

Min. 9" X 24" X 0.100 Extruded Aluminum With Double Faced Green ReflectORIZED H.I.P. Background Per Standard Specs, Sec 912.10 And 6 White ReflectORIZED H.I.P. Type IV, Series C Mixed Case Letters. Far Left And Far Right Spacing Shall Be Used For Character Placement.

DETAIL "A"

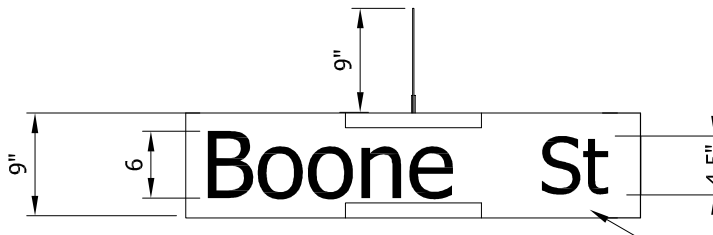
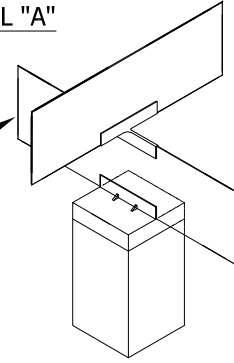

STREET SIGN SIZE

Min. 9" X 24" X 0.100 Extruded Aluminum With Double Faced Green ReflectORIZED H.I.P. Background Per Standard Specs, Sec 912.10 And 6" White ReflectORIZED H.I.P. Type IV, Series C Mixed Case Letters. Far Left And Far Right Spacing Shall Be Used For Character Placement.

1. Private Streets Shall Be So Indicated On The Left Hand Side Of The Sign With Dual Line 1-1/2" Black Letters On Yellow ReflectORIZED Background Preceding The Street Name.
2. One Sign Assemble Shall Be Located At Each Intersection On The Northeast Corner When Possible.
3. Stop Signs Shall Not Be Installed On The Street Name Sign Posts.
4. All Hardware To Be Galvanized Steel
5. For Additional Information See MUTCD.
6. All Sign Posts Shall Be Mounted On Breakaway Anchors.

REVISED APRIL 2021

BOONE COUNTY HIGHWAY DEPARTMENT

**STREET NAME SIGNS
(DETAILS)**



STANDARD DRAWING

NO. BC-900-002

SHEET 1 OF 1

SCALE: NO SCALE

SDATES 1 5TIMES 1 \$FILEL\$