



**DRIVEWAY & APPROACH PERMIT APPLICATION  
AND ENCROACHMENT AGREEMENT**

Boone County Highway Department  
1955 Indianapolis Ave  
Lebanon, IN 46052  
P: (765) 482-4550 F: (765) 483-4451

PERMIT #: \_\_\_\_\_

***APPLICANT INFORMATION (TO BE COMPLETED BY APPLICANT AND PROPERTY OWNER)***

Project Address: \_\_\_\_\_ Civil Township: \_\_\_\_\_ Access To: \_\_\_\_\_  
(Street Name)

Subdivision (If Applicable) \_\_\_\_\_, Section \_\_\_\_\_, Lot # \_\_\_\_\_

Applicant: \_\_\_\_\_ Property Owner: \_\_\_\_\_  
(if different than Applicant, indicate if same)

Mailing Address \_\_\_\_\_ Mailing Address \_\_\_\_\_

City, State, Zip \_\_\_\_\_ City, State, Zip \_\_\_\_\_

Phone: \_\_\_\_\_ Phone: \_\_\_\_\_

Email: \_\_\_\_\_ Email \_\_\_\_\_

<i>Permit Type</i>	<b><i>PERMIT TYPE*</i></b>		<i>Permit Bond Required</i>
	<i>No. of Permits</i>	<i>Permit Fee</i>	
<b>Field Entrance</b> (only for access to agricultural field)	_____ @ \$ 25 each = _____	@ \$ 0	_____
<b>Residential Drive</b>	_____ @ \$ 150 each = _____	@ \$ 0	_____
<b>Utility Pull-Off Drive</b> (for unmanned utility facilities)	_____ @ \$ 250 each = _____	@ \$ 10,000 per drive = _____	_____
<b>Minor Commercial Drive</b> (tapers only)	_____ @ \$ 250 each = _____	@ \$ 10,000 per drive = _____	_____
<b>Major Commercial Drive</b> (w/tapers and auxiliary lanes)	_____ @ \$ 250 each = _____	@ \$ 15,000 per drive = _____	_____
<b>Public Road Approach/Private Road Approach</b>	_____ @ \$ 400 each = _____	@ \$ 15,000 each = _____	_____
<b>Construction/Temporary Drive</b>	_____ @ \$ 100 each = _____	@ \$ 10,000 per drive = _____	_____
		<b>TOTAL PERMIT FEE = _____</b>	<b>TOTAL PERMIT BOND = _____</b>

<b><i>SUBMITTALS</i></b>		
<i>Purpose</i>	<i>Submittals Required</i>	<i>Submitted with Application</i>
<b>Field Entrance or Residential Drive</b>	Layout sketch w/north arrow, basic dimensions, permit bond, and R/W conveyance documents	
<b>Commercial or Utility Pull-Off Drive</b>	Scaled engineering drawings, permit bond, and R/W conveyance documents	
<b>Lane Restriction for Construction</b>	Maintenance of Traffic Plan	
<b>Construction/Temporary Drive</b>	Layout sketch w/ north arrow, basic dimensions, and permit bond	

***SIGNATURE AND CERTIFICATION***

The undersigned certifies that they have the authority to make this application and bind Property Owner(s) and owner's heirs to its terms, that the above information is true and correct, and that work requested by this application will be in conformance with the laws of Boone County. I, and all persons performing the work authorized by this permit, have read, fully understand, and will abide by all requirements concerning the permit and construction requirements. The applicant and Property Owner agree and understand that Boone County's approval is limited to conveying its approval to install the approved traffic control devices only within its legal road right-of-ways. The applicant, the Property Owner of the traffic control devices being installed under this permit, and I understand that in the event Boone County determines that any of the traffic control devices installed under this permit need to be repaired or maintained, relocated, or removed from the right-of-way, that the Property Owner or owner of the traffic control devices agrees to maintain, relocate or remove these facilities in a timely manner at no cost to Boone County.

\_\_\_\_\_  
\_ Signature of Applicant

\_\_\_\_\_  
Signature of Property Owner, if different than Applicant

\_\_\_\_\_  
\_ Printed Name

\_\_\_\_\_  
Printed Name

\_\_\_\_\_  
\_ Date

\_\_\_\_\_  
Date

## GENERAL PERMIT TERMS

- (1) A drive is not permitted to cross a limited access rights-of-way or a non-access easement.
- (2) The entire expense of constructing driveways, mailbox approaches, utilities, and other private improvements shall be borne by the Property Owner(s).
- (3) No entrance shall be closer than five (5) feet to the adjacent property line or as indicated by the AG zoning bufferyard requirements.
- (4) No approach shall be constructed so that any part of it extends in front of the property belonging to a person other than the permittee.
- (5) All driveways and approaches shall be so constructed that they shall not interfere with drainage of, or cause erosion to, the highway.
- (6) All water must be directed away from the roadway to side ditches or other swales.
- (7) The right of way area adjacent to or between two approaches may be graded at the permittee's expense, subject to the drainage requirements of the Boone County Highway Department.
- (8) All disturbed areas shall be seeded or sodded within 30 days of completion to prevent erosion. This work may be deferred until growing season upon installation of erosion control measures at the Highway Engineer's discretion.
- (9) The construction of such driveways and approaches shall not interfere with any existing structure or any county highway right of way without specific written permission from the Highway Department and any owner of the structure.
- (10) Concrete headwalls or any other concrete, brick or other solid structures will not be permitted in the right of way.
- (11) All entrances and approaches shall be constructed with adequate sight distance in both directions along the highway to allow safe access to the highway without interfering with traffic on the highway.
- (12) No entrance or approach shall be constructed where it will interfere with or prevent the proper location of highway signs.
- (13) If the driveway has a loose aggregate surface, it is the permittee's responsibility to keep the highway pavement free from the loose aggregate at all times during construction.
- (14) Permitted work must be completed within one (1) year after the permit is issued; otherwise the permit will expire and a new permit will be required.
- (15) Permittees and Property Owner(s) shall bear all expenses of keeping approaches, culverts, and drainage in proper and adequate repair.
- (16) The permittee may not plant flowers, shrubs, or trees within the right of way. Existing plantings in the right-of-way creating a potentially dangerous condition as determined by the Highway Engineer shall be removed by permittee.
- (17) During construction of any drive, the approach must have sufficient aggregate during construction to prevent damage to the edge of existing pavement.
- (18) Permittee will be responsible for costs incurred by the Highway Department to repair the existing road or public improvements if damaged.

## ENCROACHMENT AGREEMENT TERMS

1. Boone County hereby consents to Property Owner's Encroachment described in this permit to be located upon the County's right-of-way effective upon approval of the work covered by this permit.
2. The Property Owner(s) and his successors and assigns, including subsequent property owners, assumes responsibility for all maintenance of the encroaching improvement. If a driveway has a loose aggregate surface, it is the Property Owner's responsibility to keep the highway pavement free from the loose aggregate at all times.
3. Alterations of any drive or change of use of the property will require a new permit.
4. It is mutually understood and agreed that consent to the Encroachment does not create in the Property Owner or his successors and assigns any right, title, or interest in and to the County's right-of-way upon which said Encroachment is or may hereafter be located, and the Property Owner hereby specifically waives any right, title, and interest in and to that portion of the real estate owned or controlled as right-of-way which the Property Owner might have acquired, or might hereafter acquire by any means of adverse possession.
5. In consideration of the County's consent to the Encroachment on the right-of-way, Property Owner agrees to maintain the Encroachment improvements, including the culvert pipe, end sections, and drainage ditches impacted by the permitted work, in a manner which does not interfere with the use of the right-of-way for its dedicated purpose. Property Owner further agrees to maintain that portion of the private improvement within the right-of-way in good condition in substantial compliance with the standard details and specifications published at the time of the work and in such a manner as to prevent obstruction, interference, or degradation of the roadway, or negatively impact the traffic thereon or the flow of runoff water to or within any roadside ditch.
6. In consideration of the County's consent to the Encroachment on the right-of-way, the Property Owner does hereby certify, acknowledge, and affirm that Boone County, Indiana, shall not be responsible or liable for any loss occasioned by the removal, alteration, or destruction (in whole or in part) of the installation of the Encroachment over, above, and/or located upon or within the right-of-way, whether during the lawful exercise of the County's right and duties in regard to the maintenance, repair, or improvements to or upon said right-of-way or on other occasions and whether caused in whole or in part by the negligence of the County or its employees, agents, contractors, or representatives. The County and its employees, agents, contractors, officials, and other representatives are hereby released from financial responsibility for any and all losses the Property Owner incurs arising out of, related to, or associated with the Encroachment.
7. Land Owner and successors and assigns and successor owners in interest shall indemnify Boone County, Indiana, and hold the County harmless from any and all liability, damages, expenses, and costs, including reasonable attorney fees, arising out of or related to damages to property or injury to persons, including death, which result from, relate to, or arise in connection with the Encroachment within the right-of-way. In the event it becomes necessary for Boone County to enforce this indemnification and hold

harmless provision, the Property Owner shall pay all reasonable costs the County incurs in the enforcement thereof and in the enforcement of this Encroachment Agreement, including reasonable attorney fees. The Property Owner and successors and assigns and successor owners in interest to the Real Estate shall have an affirmative duty to inform all third parties with whom each negotiates for a possible sale, lease, assignment, mortgage, or transfer of the Property of the existence of this Encroachment Agreement and the obligations hereunder.

8. In the event the Property Owner or successors and assigns or a successor owner in interest to the Real Estate breaches this Encroachment Agreement, in addition to all other legal and equitable rights and remedies the County may have, the Property Owner hereby covenants and agrees that the consent granted to encroach may be revoked at any time thereafter upon the County giving at least ninety (90) days prior written notice of termination of the Encroachment. Upon receipt of such notice, the Property Owner shall remove the Encroachment at his sole cost and expense prior to the termination date. Should he or his successors and assigns fail to timely remove the Encroachment, the County may do so and is hereby released from any and all liability resulting from or associated with said removal of the Encroachment and from any diminution in the value of the Real Estate as a result thereof. All costs and expenses incurred to effectuate said removal, including related employee and court costs and attorney fees, shall be promptly reimbursed by the Property Owner to the County within ten (10) days of being invoiced.
9. When County-controlled right-of-way is transitioned to control by another governmental agency, such as an annexation or a transition from rural to urban service districts in Zionsville, permittee's obligations under this encroachment agreement shall be transferred to such governmental agency.
10. Property Owner shall be responsible to modify or remove private improvements covered by this encroachment to the Highway Engineer's satisfaction in the event the County constructs or causes to be constructed improvements within its right-of-way that are in conflict with the County work.

**Do not write in this Section - Highway Department Use Only**

Check or money order #: \_\_\_\_\_ Web Payment ID# \_\_\_\_\_ TOTAL PERMIT FEE \$ \_\_\_\_\_

\*Bond Company: \_\_\_\_\_ Bond Amount: \$ \_\_\_\_\_ Bond #: \_\_\_\_\_

Date on Dedication Documents (if Applicable) \_\_\_\_\_ TOTAL PERMIT BOND \$ \_\_\_\_\_

**Do not write in this Section - Highway Department Use Only**

**Permit Bond Required?**

Yes Value of Bond Required: \_\_\_\_\_  
 No

**Pipe Required?**

Yes No

Size: \_\_\_\_\_

**Legal Drain Affected?**

Yes Legal Drain(s) Affected: \_\_\_\_\_  
 No

Type: \_\_\_\_\_

If yes, Surveyor must be in agreement

Boone Co. Surveyor Agreement: \_\_\_\_\_

Note: Reference Boone County Standards 600 Series Standard Drawings. These can be found at <https://boonecounty.in.gov/offices/highway/standard-drawings/>

**Right of Way Dedication Required?**

Yes Thoroughfare Classification: \_\_\_\_\_  
 No Width per Thoroughfare Plan: \_\_\_\_\_

**This permit is approved:**

As submitted Subject to the changes noted on the plans Subject to the attached conditions  
 Other: \_\_\_\_\_

**Mailbox Approach Required?** Note: Please see (10) of General Permit Terms and Boone County Standard Drawing BC-603-009.

Yes : Contact local mail carrier for mailbox location.  
 No

Inspector: \_\_\_\_\_ Date: \_\_\_\_\_

Director of Highways: \_\_\_\_\_ Date: \_\_\_\_\_ Expiration Date: \_\_\_\_\_

**Final inspection (Upon signing, this document becomes your Encroachment Agreement):**

Inspector: \_\_\_\_\_ Date: \_\_\_\_\_  
 (print)

\_\_\_\_\_  
 (sign)

**DRIVEWAY & APPROACH  
APPLICATION, PERMIT, AND ENCROACHMENT AGREEMENT**

**Instructions for Completion:**

1. Complete the Applicant Information and Permit Type information using a computer or printed in black ink. Any non-applicable blanks must be marked N/A.
2. Provide the indicated submittals, depending on the type of work proposed. Check the box for the submittals provided.
  - a. Layout sketches shall be no larger than 11"x17". The sketch must show the edge of pavement, basic construction details, existing driveways, existing drainage easements and other significant features within or immediately adjacent to the R/W (including septic system laterals and perimeter drains). The sketch must show distances to a permanent landmark, dimensions of all construction, and have a legend for all symbols used.
  - b. Scaled engineering drawings must show private improvements along with the R/W; edge of road shoulders, all construction details, important elevations, existing and proposed contours, existing driveways, existing drainage, easements and other significant features within or immediately adjacent to the R/W. The plan must show distances to the nearest intersecting roads, dimensions of all construction and have a legend for all symbols used.
3. The permit bond amount is based on the type and amount of work being authorized by this permit. A higher amount may be required upon review of the application. The beneficiary on the permit bond shall be the "Boone County Board of Commissioners, Boone County, Indiana". The standard bond amounts shall be set forth in the Schedule of bonds for the Boone County Highway Department as approved by the Boone County Commissioners.
4. Permit fees shall be paid by check or money order (or credit card if processing is available) made payable to the "Boone County Highway Department". Cash cannot be accepted.
5. When complete, mail or hand deliver this signed application, permit bond and other submittals to the above address. Once the permit has been approved by the inspector, payment may then be made.

**What Happens Next:**

1. The Boone County Highway Department will review this application. If the application is incomplete, the application form and submittals will be returned to you. If the application is complete, a highway department inspector will call you to schedule a site visit to review the site conditions before approving the permit.
  - a. You shall meet the inspector on the site during the inspection.
2. The project site must be clearly marked during the inspection where the drive or other improvement is to be installed.
3. During the inspection, issues may be identified that require changes or additions to the application. If you can meet the inspector, these issues can be discussed with you. If you cannot attend the inspection, the highway department will mail to you an inspection report outlining the inspection results and additional information needed for the application. If we do not receive this additional information within 30 days, we will return the permit and other documentation to you, less the permit application fee (which covers the inspection).
4. Once the inspection is complete and all needed information is provided, the highway department will process your application.
5. Once installation of driveway, culvert (if applicable), mailbox and mailbox approach (if applicable), and all drainage improvements have been completed, please notify Boone County Highway for Final Inspection.

**I acknowledge that to obtain a Certificate of Occupancy, the driveway shall be installed per these standards and I will request the final inspection 5 days prior to the anticipated date of obtaining a Certificate of Occupancy. I understand that a Temporary Certificate of Occupancy is not an option.**

**Applicant:** \_\_\_\_\_ **Date:** \_\_\_\_\_

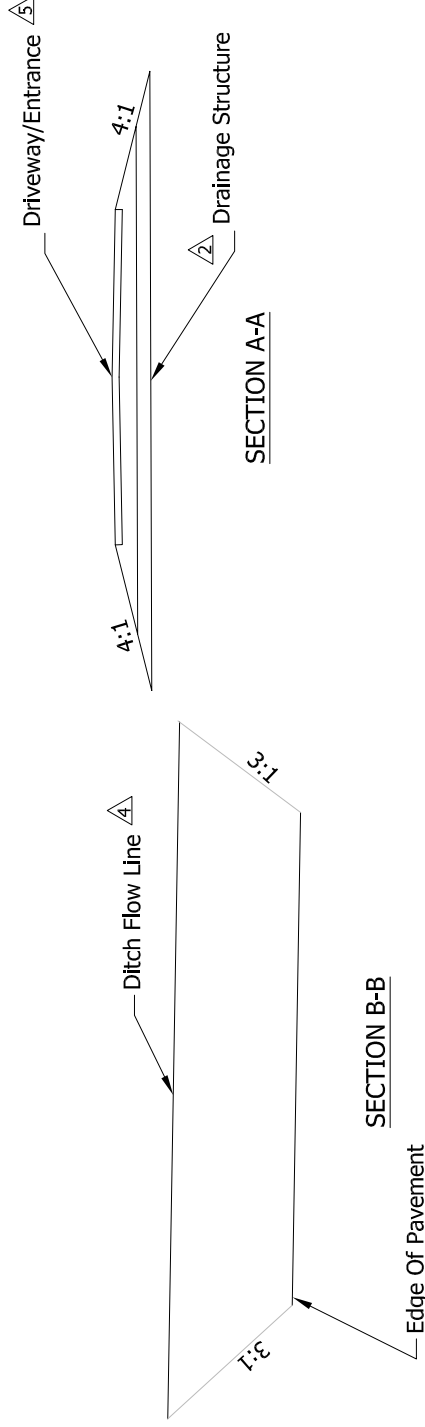
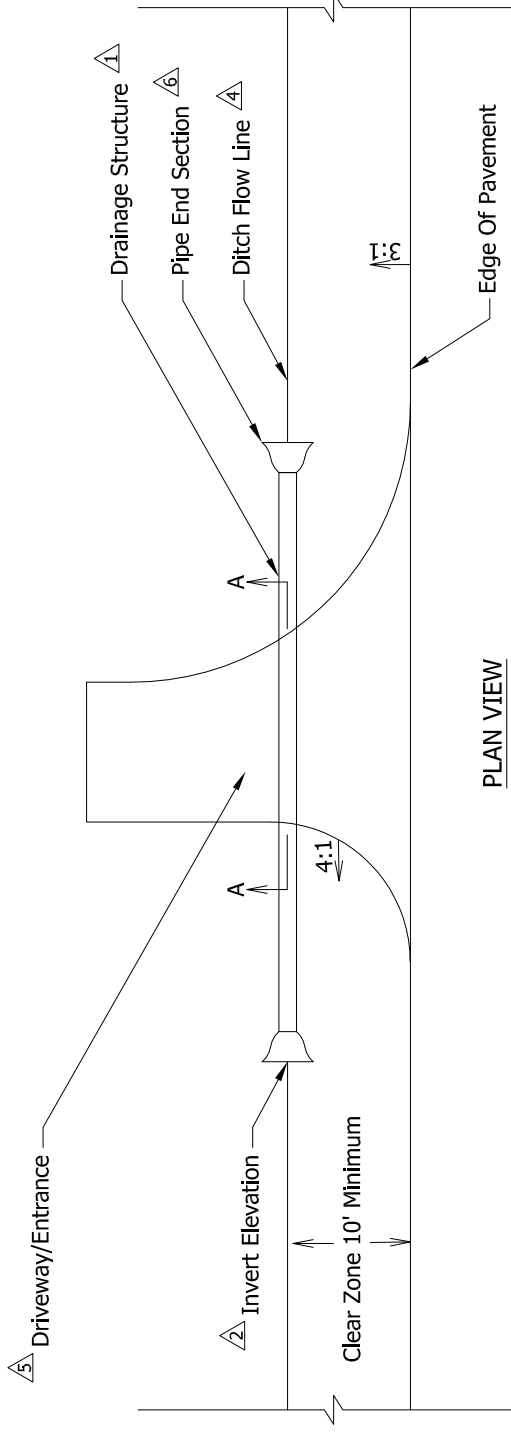

**NOTES:**

- 1. 12" Min. Diameter Structure (15" Diameter Desirable)  
Or As Directed By Boone County Engineer, Minimum 12" Cover
- 2. Invert Elevations Shall Be Provided At All Downstream And Upstream Inverts.
- 3. Any And All Necessary Ditch And Drainage Improvements Shall Be Provided By Individual Performing The Installation
- 4. Flow Line Elevations Shall Be Provided At The Beginning, End, And Every Grade Break.
- 5. For Subdivision Residential Driveway Details - See STD Drawing BC-603-001  
For Urban Commercial Driveway Details - See STD Drawing BC-603-002  
For Field Entrance Details - See STD Drawing BC-603-003  
For Rural Residential Drive - See STD Drawing BC-603-004
- 6. Pipe End Sections Shall Be In Accordance With Clear Zone Criteria Outlined In Current Version Of AASHTO Roadside Design Guide  
Drainage Structure Should Be a Min of 10' From Edge Of Pavement

REVISED MAY 2021



**BOONE COUNTY HIGHWAY DEPARTMENT**

**TYPICAL CULVERT DETAIL WITH OPEN DITCHES**

STANDARD DRAWING  
NO. BC-603-010  
SHEET 1 OF 1  
SCALE: NO SCALE

27/2019 11:10:32:45 AM P:\170004 - Boone County As-Needed Assistance\Standards\09Road\04 Design files\02 DGN\Plans\6005\603-003\_Field Drive\_Sht\_Typical.dgn

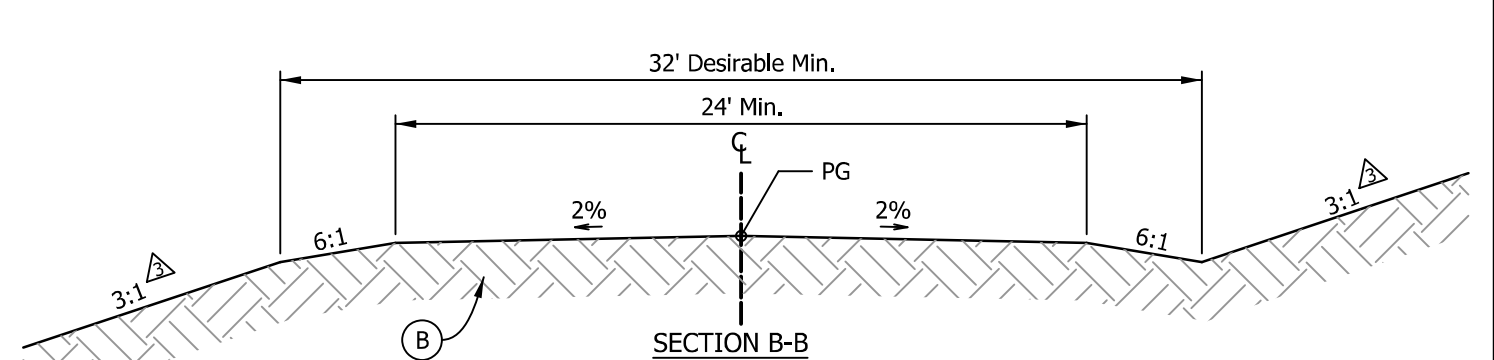
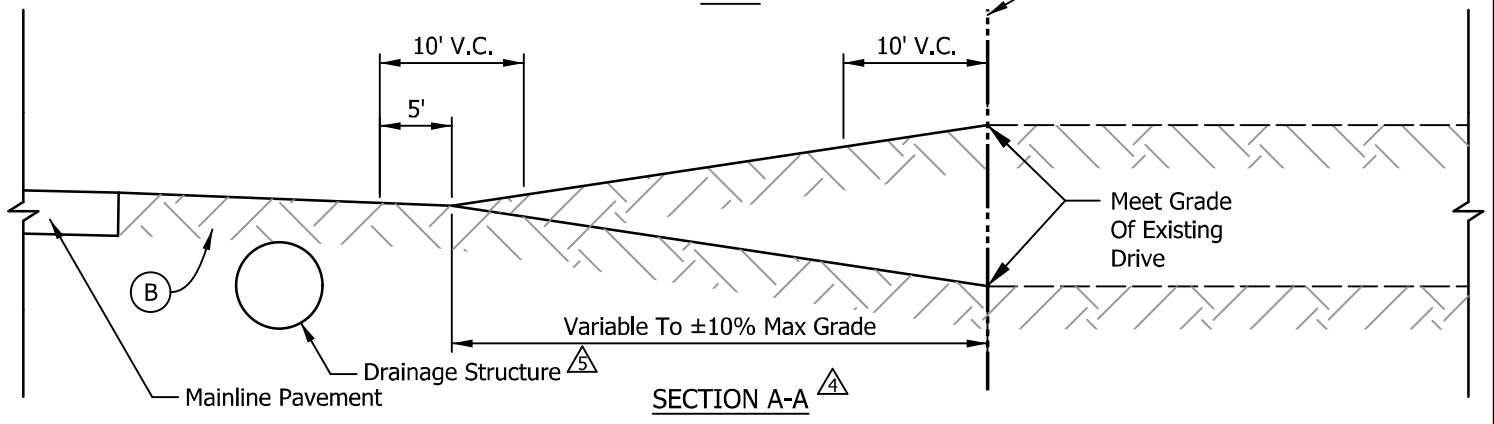
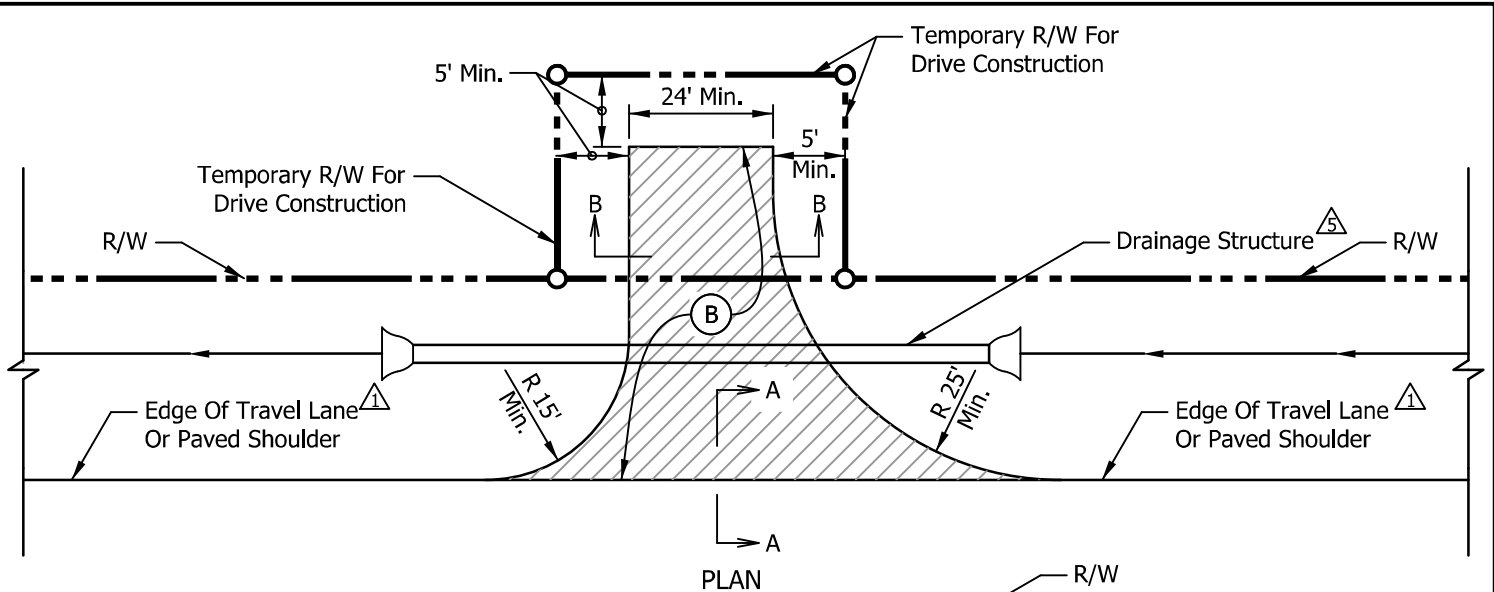

**NOTES:**

- 1. Where The Shoulder Is Earth Or Aggregate, Or When The Paved Shoulder Is Less Than 8', The Drive Radii Shall Be Tangent To The Travel Lane. Where The Paved Shoulder Is 8' Or More, The Drive Radii Shall Be Tangent To The Paved Shoulder
- 2. Driveway Culverts Which Cannot Be Located Outside Of The Clear Zone Shall Require Grated End Sections In Accordance With INDOT Standards
- 3. Foreslopes And Backslopes Shall Be In Accordance With Clear Zone Requirements Set Forth By INDOT Design Manual (Current Edition)
- 4. Minimum 2% Grade For 10' Away From Edge Of Pavement Required For Gravel Drives
- 5. For Drainage Structure Details - See STD Drawing BC-603-010

**LEGEND:**

(B) Earth Fill Or Aggregate As Needed

**BOONE COUNTY HIGHWAY DEPARTMENT**

**TYPICAL FIELD ENTRANCE**



STANDARD DRAWING
NO. BC-603-003
SHEET 1 OF 1
SCALE: NO SCALE

2/7/2019 11:10:32:46 AM P:\170004 - Boone County As-Needed Assistance\Standards Consultation\09Road\04 Design Files\02 DGN\Plans\6005\603-009\_BC\_Mailbox Approach\_Sht\_Typical.dgn

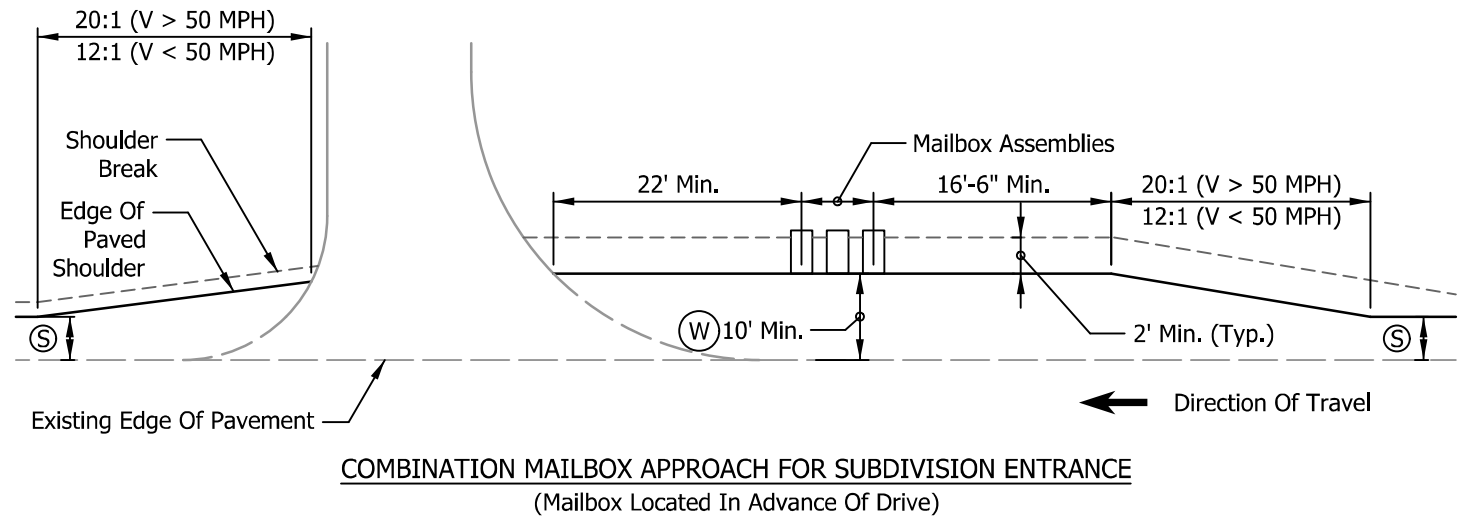
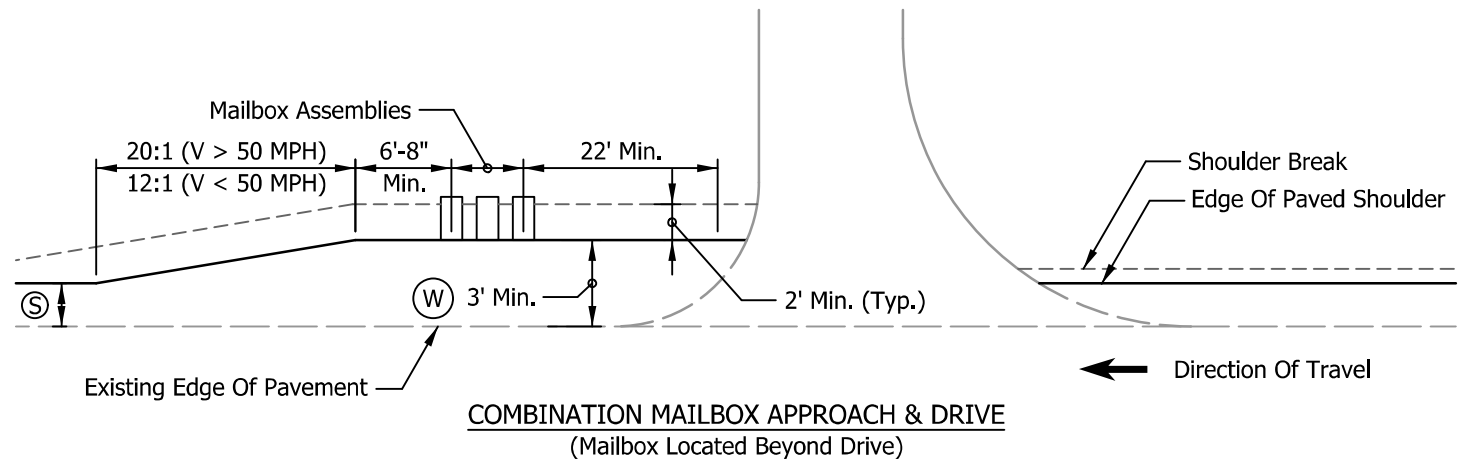
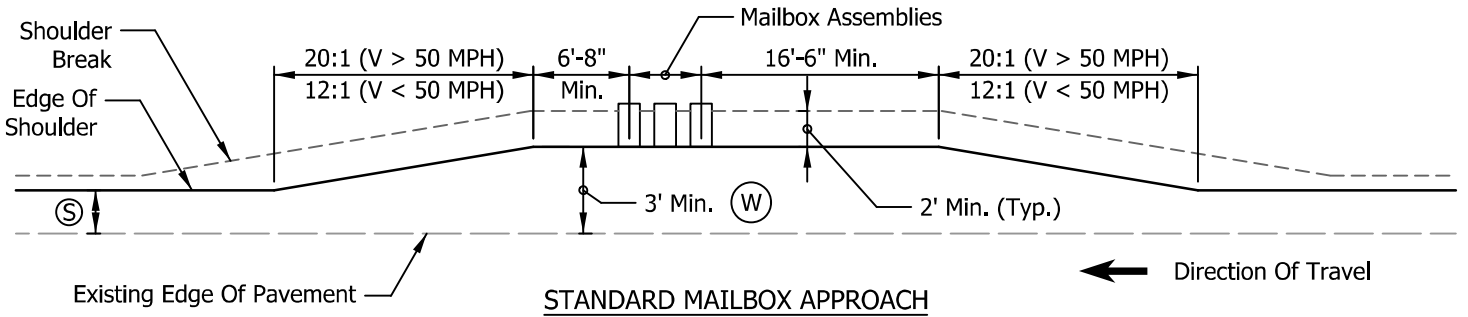

**LEGEND:**

- (W) Match Existing Adjacent Pavement Section (Shoulder Or Lane)
- (S) Shoulder Width From Plans

**BOONE COUNTY HIGHWAY DEPARTMENT**

**TYPICAL MAILBOX APPROACH**



STANDARD DRAWING
NO. BC-603-009
SHEET 1 OF 1
SCALE: NO SCALE

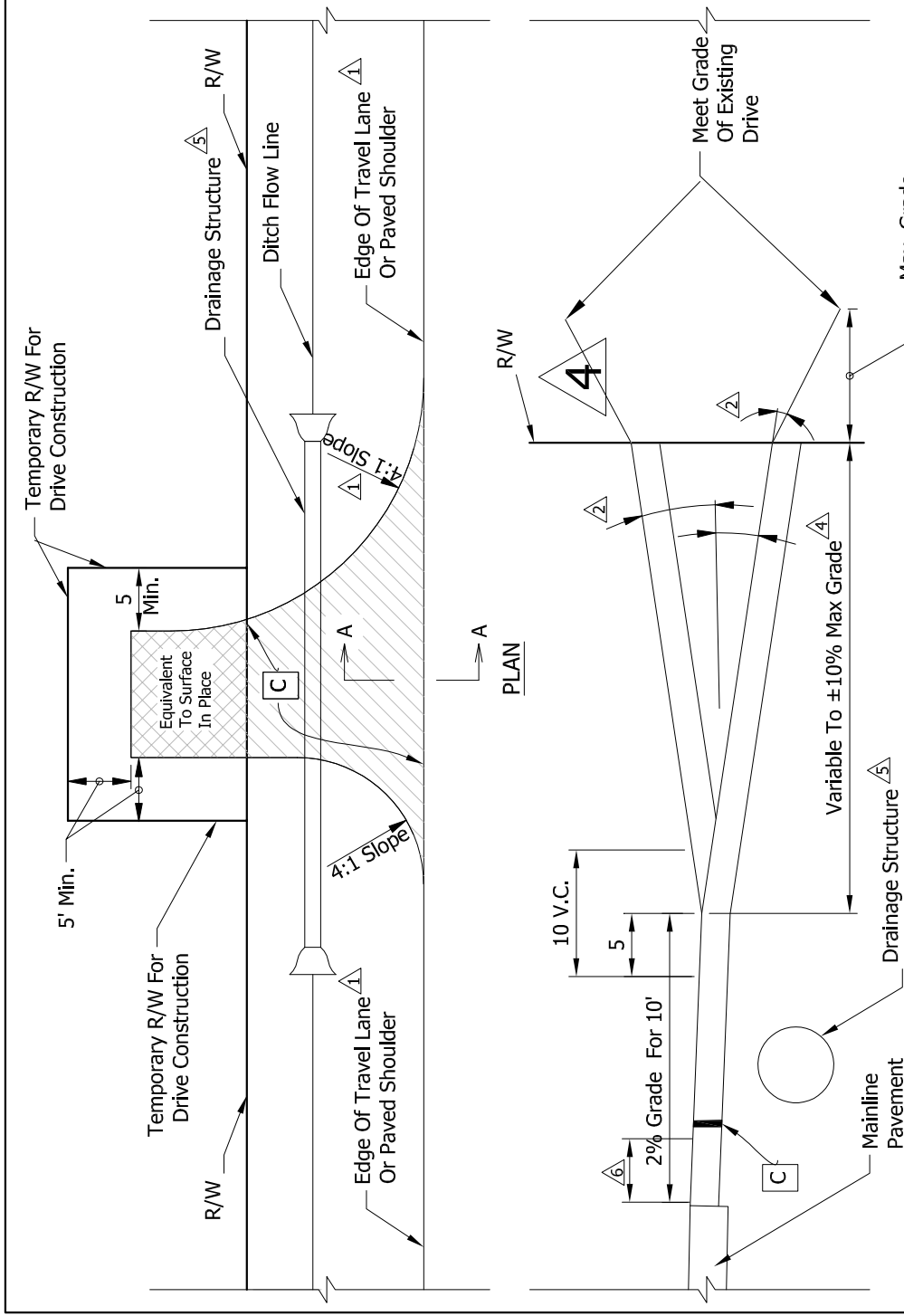

SECTION A-A

LEGEND:

Pavement Layer	Asphalt	Concrete	Aggregate	Mainline Resurfacing
HMA Surface, Type B	1.5"	-	-	per plan
HMA Intermediate, Type B	3.5"	-	-	per plan
HMA Base, Type B	-	-	-	N/A
Compacted Aggregate No. 53	-	-	6"	N/A
INDOT Subgrade Treatment	Type II	Type II	Type II	N/A
PCCP for Approaches	N/A	6"	N/A	N/A
Minimum Width for HMA Approach	N/A	2'	N/A	2'

NOTES:

- 1 Where The Shoulder Is Earth Or Aggregate, Or When The Paved Shoulder Is Less Than 8', The Drive Radii Shall Be Tangent To The Travel Lane. Where The Paved Shoulder Is 8' Or More, The Drive Radii Shall Be Tangent To The Paved Shoulder
- 2 Max. Algebraic Diff. In Grades; Crests 8.00%, Sags 12.00%
- 3 Driveway Culverts Which Cannot Be Located Outside Of The Clear Zone Shall Require Grated End Sections In Accordance With INDOT Standards. Drainage Structure Should Be Minimum Of 10' From Edge Of Pavement (Clear Zone)
- 4 Minimum 2% Grade For 10' Away From Edge Of Pavement Required For All Drives. 2.5" For Every 10' From Edge of Pavement
- 5 For Drainage Structure Details - See STD Drawing BC-603-010

REVISED MAY 2021

**BOONE COUNTY**  
Highway Department

**BOONE COUNTY HIGHWAY DEPARTMENT**

**TYPICAL RURAL RESIDENTIAL DRIVEWAY**

STANDARD DRAWING  
NO. BC-603-004  
SHEET 1 OF 1  
SCALE: NO SCALE



2/7/2019 11:10:32:45 AM P:\170004 - Boone County As-Needed Assistance\Standards Consolidation\09Road\04 Design Files\02 DGN\Plans\6005\603-001\_BC\_Res\_Drive\_Sht\_Typical.dgn

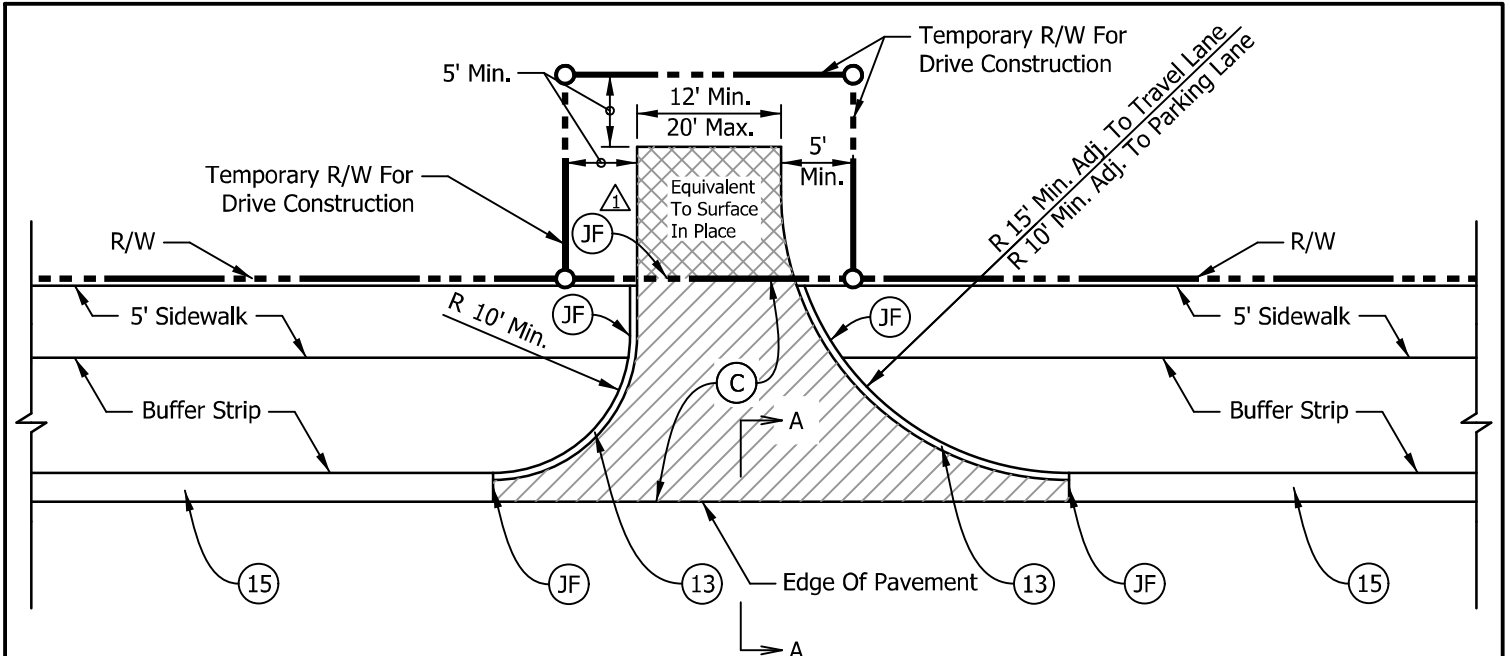

PLAN

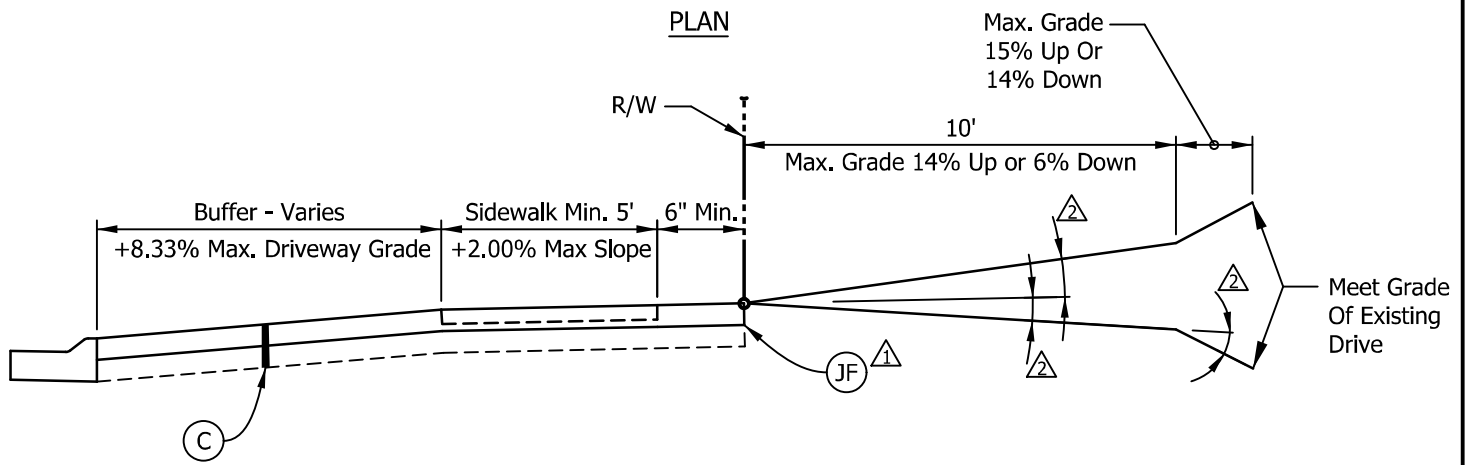

SECTION A-A

LEGEND:

Symbol	Pavement Layer			
	Asphalt	Concrete	Aggregate	
⊙	HMA Surface, Type B	-	-	-
⊙	HMA Intermediate, Type B	-	-	-
⊙	HMA Base, Type B	-	-	-
⊙	Compacted Aggregate No. 53	-	-	-
⊙	INDOT Subgrade Treatment	-	Type II	8"
⊙	PCCP for Approaches	N/A	6"	N/A

- ⊙ 1/2" Preformed Joint Filler
- ⊙ Monolithic Curb See STD Drawing BC-601-001
- ⊙ Concrete Curb And Gutter See STD Drawing BC-601-001

NOTES:

- Joint Filler Required When Existing Drive Is PCCP
- Max. Algebraic Diff. In Grades; Crests 8.00% Sags 12.00%
- 8" Compacted Aggregate May Be Substituted For PCCP With Approval From County Engineer
- 4. Sidewalk Elevation Transitions At Drives To Be In Compliance With Current ADA Guidelines
- 5. Driveway Culverts Which Cannot Be Located Outside Of The Clear Zone Shall Require Grated End Sections In Accordance With INDOT Standards
- 6. For Drainage Structure Details See STD Drawing BC-603-010

BOONE COUNTY HIGHWAY DEPARTMENT

TYPICAL SUBDIVISION RESIDENTIAL DRIVEWAY



STANDARD DRAWING
NO. BC-603-001
SHEET 1 OF 1
SCALE: NO SCALE